

# Ranger Open Game

## GENERAL SPECIFICATIONS

### MECHANICAL

- 2.5 Turbo Intercooler Diesel • 5 Speed Manual Transmission 4x4
- Differential Lock • Power Steering • Tilt Steering Column
- Remote Fuel-lid Opener • Steel Rims • Tyre Size 31x10.5 R15

### SAFETY

- Airbags (Driver and Front Passenger w. Safety belts)
- Side Intrusion Door Beam • Rear Passenger Lap Seat Belts

### WARRANTY

- 3 Years/60,000 Kms. Terms & Conditions Apply

### SEATING CONFIGURATIONS



### DIMENSIONS

Lenght 0000 x Width 0000 x Height 0000

- Addition of extra features may change figures in this chart. Vehicle body color might differ slightly from the photos in this catalog.
- Vehicles pictured and specifications detailed in this catalogue may vary from models and equipment available in your area.
- Hughes reserves the right to alter any details of specifications and equipment without notice. Details of specifications and equipment are subject to change to suit local conditions and requirements. Please inquire with us for details of any such changes that might be required for your area.



Hughes Motors (Tanzania) Ltd,  
P.O.Box 711, Usa River, Arusha, Tanzania.  
Telephone: +255 27 255 3682/3 - Fax: +255 27 255 3708  
Email: [info@hughesmotorstz.com](mailto:info@hughesmotorstz.com)  
[www.hughesmotorstz.com](http://www.hughesmotorstz.com)

**DISTRIBUTED: TANZANIA - KENYA - UGANDA**

E. & O. E.

Design & Photography: enricer@yahoo.it - Printed in May 2011



3 yrs.  
**Warranty**  
60,000 Kms.  
Throughout East Africa!



# Ranger Open Game Viewer

# Ranger Open Game

*Best...*

- Competitive Price
- 4x4 Ground Clearance
- Easy Access
- Operational Efficiency
- Luggage Space with Security



*Age doesn't Matter!*



*Amazing Viewing!*



*Unlimited Luggage!*



240mm Ground Clearance 320mm

Design © RSA Ltd. Property

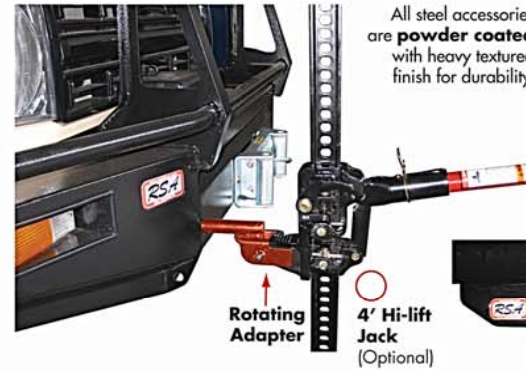

All steel accessories are **powder coated** with heavy textured finish for durability.



**Rear Protection Bar** consisting of hi-lift jacking points and pulling facility.



Seats designed for comfort, safety seat belts, for long distance travel.

Mobile Fridge  
40 Liters (12 Volts)



Electric Winch  
9500 Lbs

Inverter & Power Outlet  
240 AC - 50 Hz (300 Watts)



## OPTIONALS

- Sides Covers w. windows
- Sides Shade Nets
- Console Box
- Fridge Bracket
- Lamp Grills Set
- Snorkel
- Radiator Screen
- Tow Ball 50mm
- Trailer Socket